

**PLEASE READ AND UNDERSTAND ALL SECTIONS IN THIS MANUAL BEFORE YOU BEGIN YOUR INSTALLATION.**  
For additional information please visit [inhaussurfaces.com](http://inhaussurfaces.com) or call 1.888.255.3412.

## CAUTION:



- If using power tools to cut planks, always cut in a well-ventilated area.
- Never use tools designed for other flooring installation systems (eg. seam rollers, tap blocks, etc.).
- Do not directly hit or press Ceramin® Icon with any installation tools such as tap blocks, hammers, mallets or seam rollers as this can cause damage to the product's locking system.
- Never wax, polish or use abrasive cleaners on Ceramin® Gallery floors as they may damage the floor's finish beyond repair.
- Ceramin® Icon is not recommended in areas where the floor might experience temperature extremes beyond -40°F (-40°C) or greater than 150°F (65°C).

## INTENDED USE

Ceramin® Icon floors are intended for indoor use only and can be installed in any room as long as it does not have in-floor drainage. All Ceramin® Icon floors have been designed to withstand the requirements of the busiest households as well as light commercial applications. Light commercial is defined as environments with light to moderate foot traffic, light point loads and lack of rolling loads. Light commercial areas exclude areas with exposure to chemicals, acids, greases or other such contaminants. If you are unsure of Ceramin's suitability for your application, please contact Inhaus at 1.888.255.3412 before installing the product to confirm warranty coverage.

## HANDLING

- Handle Ceramin® Icon with care prior to installation; protect the product's edges, do not drop cartons, etc.
- Always store Ceramin® Icon cartons flat and properly supported on a level surface.
- Never lean cartons against walls and do not store them on saw-horses or similar equipment that does not fully support the full length of the cartons.

## PRE-INSTALLATION

**Prior to installing, check all planks for color against samples used in selection to ensure correct product. Further, inspect for defects and transportation damage. Any planks that show damage or defects should not be used.**

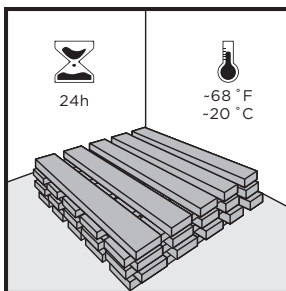

## ACCLIMATION

Acclimation is not required but is recommended as a best practice. However, acclimation is required if the product has been exposed to extreme temperatures within 12 hours before the installation. Do not install cold/frozen planks as they could be brittle.

To acclimate, cross-stack unopened boxes of flooring in the installation room at room temperature for at least 24 hours before starting the installation. The temperature must be maintained at room temperature or around 68°F (20°C) before and during the installation.

## PRE-INSTALLATION CONTINUED

### UNDERLAY

This product comes with a pre-attached underlay so the use of a secondary is not required. If you choose to use a secondary underlay to improve the acoustical properties of your floor, use only underlays from Inhaus' Approved Underlay List. Note that the use of a secondary underlay that is not on Inhaus' Approved Underlay list should not be used and will void the product's warranty.

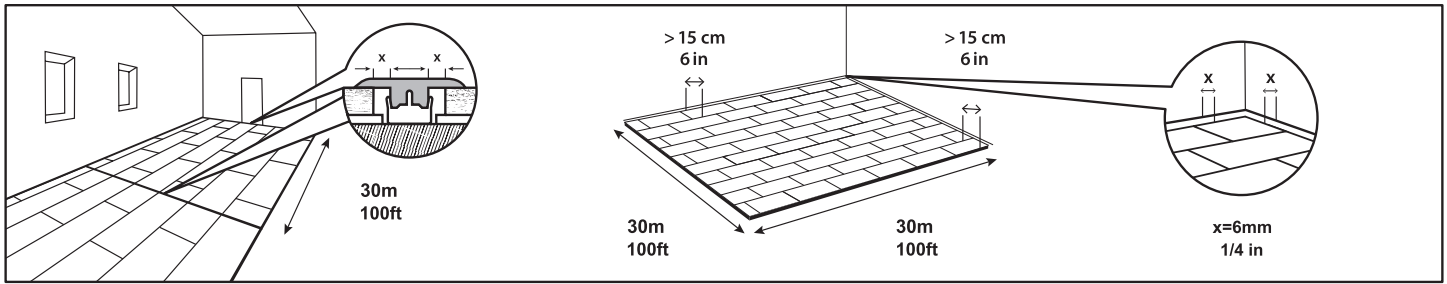

### EXPANSION SPACE

It is necessary to leave a 1/4" (6mm) expansion space around the perimeter of the room and all other objects (e.g. toe kicks, plumbing, etc.). The expansion space will be covered by the wall base or quarter round once the floor is installed. If installing in moisture prone areas, please refer to the Recommendations for Wet Area Installation section of this guide.

### MAXIMUM ROOM SIZE

Ceramin® Icon floors can be installed up to 100 linear feet (30m) in length and/or 100 linear feet (30m) in width. Installations in rooms that are over 100 linear feet (30m) in length or width must use transitions.

### INSTALLATION LAYOUT

There are no rules when it comes to the direction you choose to lay planks in your installation. Typically, Ceramin® Icon flooring installations are oriented parallel to the longest wall in the room, or perpendicular to the main window in the room.

### CUTTING PLANKS

Ceramin® Icon flooring planks are designed to be cut using a score and snap method using a standard utility knife. Simply score planks and bend to snap or cut. Always use a straight edge and appropriate safety equipment when scoring and snapping planks. It is important to use good quality, sharp blades in order to minimize damage to the planks. Ceramin® Icon planks can also be cut with guillotine-type flooring cutters and power saws (e.g. circular saw, table saw, miter saw, jigsaw) as well as hand saws.

**NOTE: Ceramin® Icon planks should always be cut away from the installation area in order to minimize debris and dust in the installation site. Always wear protective equipment such as safety glasses, a NIOSH-approved dust mask and gloves.**

### TOOLS AND MATERIALS REQUIRED

- Measuring tape
- Pencil or marker
- Utility knife
- Handsaw or door jamb saw
- Saw (any of the following – not required if cutting planks using score and snap method):
- Guillotine-type cutter, Table saw, Miter saw, Circular saw, Jigsaw
- 1/4" (6mm) spacers
- Safety glasses & dust mask (NIOSH designated)
- Appropriate glue if installing in areas where planks cannot be angled (e.g. under door jambs)—
- 100% flexible neutral curing silicone caulking if installing in moisture prone areas
- PE backer rod if installing in moisture prone areas

## SUBFLOOR PREPARATION

Ceramin® Icon floors can be installed over many types of subfloors as long as they are properly prepared and meet the required criteria outlined below.

**CAUTION: If you contemplate the removal of a resilient floor covering structure that contains (or is presumed to contain) asbestos, you must review and comply with applicable local regulations. Do not sand, dry sweep, dry scrape, drill, saw, bead blast, or mechanically chip or pulverize existing resilient flooring, backing, lining felt, asphalt “cutback” adhesive, or other adhesive. These products may contain asbestos fibers and/or crystalline silica. Avoid creating dust. Inhalation of such dust is a cancer and respiratory tract hazard. Smoking by individuals exposed to asbestos fibers greatly increases the risk of bodily harm. Unless positively certain that the product is a non-asbestos containing material, you must presume it contains asbestos. See “Recommended Work Practices for Removal of Resilient Floor Coverings” (rfci.com) for detailed information and instructions on removing all resilient covering structures.**

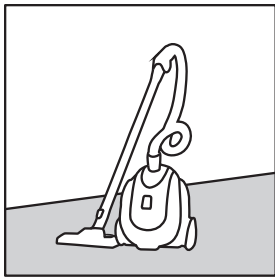

### GENERAL SUBFLOOR PREPARATIONS & PRECAUTIONS

- Subfloors must be clean and free of dirt and debris prior to installation.
- Subfloors must be structurally sound.
- Ceramin® Icon floors can be installed in bathrooms, kitchens, and entryways by following the (Wet Area Recommendations) section of this guide.
- Variations in the subfloor flatness should not exceed 3/16” per 10 ft (6mm per 3m) and 1/8” per 6 ft (3.175mm per 1.9m). Floors must be leveled to meet this specification prior to installation.
- Abrupt height differences of more than 1mm / 10cm must be corrected (for example, nail heads, concrete ridges and other similar small protrusions).
- Carpet is not a suitable underlay for Ceramin® Icon floors. All carpet, carpet pad and carpet tack must be removed prior to installation.
- Care must be taken to ensure that the subfloor meets all local building codes and regulations. If installation is below grade or on grade, foundation walls must meet all local building codes and regulations.
- Crawl spaces must meet all local building codes and regulations. Any moisture or risk of moisture existing in your crawl space should be mitigated prior to installing Ceramin® Icon.

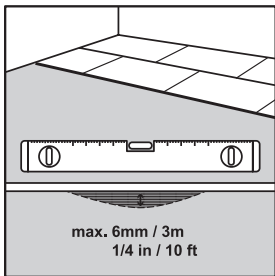

**NOTE: Ceramin® is waterproof and moisture itself will not affect the products. However, excessive moisture in the subfloor could promote mold, mildew, and other moisture related issues such as trapping of moisture underneath the flooring which may contribute to an unhealthy indoor environment.**

### CONCRETE SUBFLOORS

Concrete subfloors must be properly cured prior to installation of Ceramin® Icon.

Always test concrete subfloor for moisture prior to installation. To do so:

- Tape 3' x 3' (91cm x 91cm) pieces of polyethylene vapor barrier to subfloor.
- If condensation appears on the film after 24 hours or concrete appears dark in color, moisture is likely present and a Calcium Chloride test must be performed.

The maximum allowable moisture emission is 8.0 lbs/1000 ft<sup>2</sup> per 24 hours (3.91 kg/100 m<sup>2</sup> per 24 hours) ASTM F1869. Alternatively, a Tramex test can be performed in accordance with ASTM F2659. However, recorded values higher than 4.5% require a Calcium Chloride test to verify that the subfloor moisture is appropriate. In Situ probe testing can also be used according to ASTM F2170 and the reading should not exceed 85%.

If moisture emissions exceed the above stated thresholds, moisture mitigation is required: for a successful installation and to prevent the flooring material from being damaged by moisture from the subfloor.

## SUBFLOOR PREPARATION CONTINUED

### WOOD SUBFLOORS

- Wood subfloors must be structurally sound and screwed or nailed to supporting beams.
- Subfloor moisture must be tested prior to installation and should not exceed 12% throughout the installation area.
- Do not install Ceramin® Icon floors over wood subfloors applied directly to concrete.

### VINYL (SHEET/TILE), LINOLEUM, CERAMIC TILE

- Existing floor covering must be in good condition with no tears, cracks or chips.
- Floor covering should be well bonded to the subfloor
- Heavily cushioned floor covering (eg. cushion vinyl) and resilient floors that exceed one layer in thickness should be removed. Follow manufacturer's guidelines when uninstalling resilient floor coverings. Wear personal protection equipment (dust mask, gloves, glasses, etc.).
- If installing over ceramic tile, any abrupt unevenness of more than 1 mm / 10 cm (eg. caused by large grout areas) should be made smooth by applying a leveling compound.

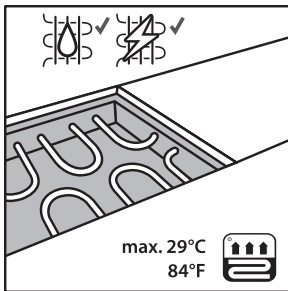

### IN-FLOOR RADIANT HEAT SYSTEMS

- Icon can be installed over 1/2" (13mm) embedded hydronic (water-based) and electric heat systems. Radiant heat systems must have a minimum of 1/2" (13mm) separation from the product. Maximum operating temperature should never exceed 29°C (85°F). Use of an in-floor temperature sensor is recommended to avoid overheating. Radiant heat mats installed directly under the floor (i.e. not embedded) are not acceptable.
- Before installing over newly constructed radiant heat systems, operate the system at maximum capacity to force any residual moisture from the cementitious topping of the radiant heat system.
- Radiant heat systems must be in operation for a minimum 3 weeks prior to installation of Icon flooring.
- Ensure subfloor meets the required specifications stated in this guide. Use moisture mitigation as stated in this installation guide.
- Before starting the installation, turn the heat off for 24 hours before, during and 24 hours after installation.
- Make sure that the temperature in the room is between 60°F (16°C) and 80°F (27°C) during installation.
- Once the installation has been completed, the heating system should be turned on and increased gradually (5°F degree increments) until returning to normal

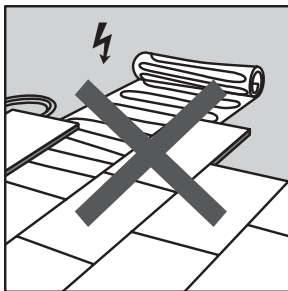

operating conditions.

- Refer to the radiant heat system's manufacturer recommendations for additional guidance.

**Warning: Electric heating mats are not recommended for use underneath the flooring and will void the warranty.**

### WALL BASE /TRIM

- Removal of existing wall base/trim is optional. If you decide not to remove your wall base then you will have to install quarter-round moldings after installation of your Ceramin® Icon floor is complete.
- Wall base or trim will need to be installed once the flooring installation is complete to cover the expansion space around the perimeter of the room.
- Always nail/adhere wall base and trim to the wall. Never nail/adhere it to the flooring.

### WALL IRREGULARITIES

Walls are not always perfectly straight. Ceramin® Icon floors will need to be cut so as to fit within irregularities of your walls. To do so:

1. Install a complete first row of Ceramin® Icon floors (following the Installation Procedures below) and ensure that all long edges of the Ceramin® Icon flooring are aligned flush with one other.

## ROOM PREPARATION

- Slide the whole row against the wall; you will now notice any wall irregularities (i.e. areas where the wall is not straight).
- Trace the contour of the wall onto the row of Ceramin® Icon flooring with a pencil or marker. Once traced, uninstall the planks carefully so as to not damage the locking system and cut along the traced line (see Plank Removal section below).
- Re-install the planks leaving the necessary 1/4" (6mm) expansion space between them and your wall.

## CABINETS & ISLANDS

- As best practice, cabinets and islands should be installed prior to installing Ceramin® Icon floors.
- Cabinets and Islands can be installed on top of Ceramin® Icon as long as they are not fastened to the subfloor in any way. Ceramin® Icon should be allowed to float and never be pinned to the subfloor by any fasteners.

## DOORS & DOOR JAMBS

Ceramin® Icon floors should be installed under door jambs. As such door jambs will need to be undercut accordingly. To do so:

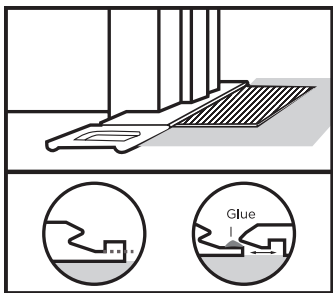

- Use a Ceramin® Icon flooring off-cut to support your saw blade at the correct height for undercutting.
- Check door clearances and make any necessary height adjustments before installing Ceramin® Icon floors.
- Make sure to leave the 1/4" (6mm) expansion spacing from the wall under the door jamb.

**TIP: If possible, it is often easiest to start at the door of the room so that the first plank can be easily slid under the door jamb.**

- In some cases you may have to modify a plank's locking system as a door jamb may prevent you from angling it into place. To do so, safely remove the vertical section of the groove. This will allow you to slide planks together horizontally. Apply a small amount of adhesive suitable for gluing polypropylene into the plank's groove and slide the plank into place.

## INSTALLATION PROCEDURE

- It is recommended that planks be mixed from at least three cartons to achieve the most natural and varied appearance. There are 18 unique planks in every Ceramin® Icon design. However, during production, the same plank may be inserted into one carton multiple times. It is important to mix planks from multiple cartons and review the installation often to ensure the most random appearance.
- Inspect every plank for damage and visual defects before installing it. **DO NOT INSTALL** damaged or defective planks.
- Never force planks together using excessive force. If planks are not fitting together easily check joint alignment and inspect for debris in the joints.
- Ceramin® Icon planks should install with thumb pressure. If the use of a mallet is desired for connecting the short ends of the planks, do not tap directly onto planks you are installing. Place a small scrap piece on top of the joint you are connecting and tap it to protect the planks you are installing. Only a small amount of force is required.
- The first and last row of the installation should be wider than 3.5" (9cm). To ensure this will be the case, prior to installation:
- Measure the width of the room and divide it by the width of the planks you are installing.

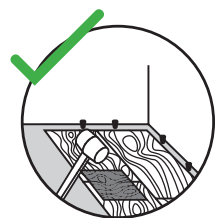
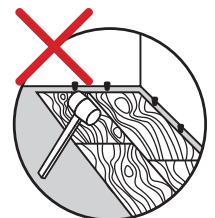

## INSTALLATION PROCEDURE CONTINUE

- If the remainder is less than 3.5" (9cm) cut 3.5" (9cm) from the width of the first row. If this is not possible, simply ensure that both edge planks are as even in width as possible.
- The first and last plank in a row should be a minimum of 16" (40cm) long.
- Stagger the planks from row to row by a minimum of 16" (40cm).
- Prepare the subfloor and room as per the corresponding instructions found in this guide.
- Use spacers to maintain the 1/4" (6mm) expansion space between the first row and the wall.
- Select a starting corner of the room and work from left to right.

### INSTALLING THE FIRST ROW

You can connect planks in your first rows in two ways:

#### Method #1:

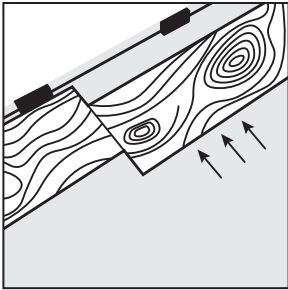

1. Lay the first plank with the long edge tongue facing the wall.
2. Lay the second plank flat on the floor and adjacent to the first plank with the short edge joint aligned with the groove of the first plank.
3. Slide the planks perpendicular to each other engaging the short edge locking system.
4. Continue in this manner until the first row is complete, cutting the last plank to complete the row.
5. Use the remainder of the last plank of the first row to start the second row provided that it is a minimum of 16" (40cm) long.

#### Method #2:

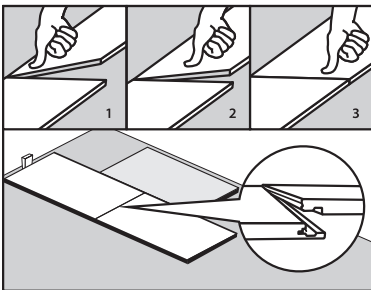

1. Lay the first plank with the long edge tongue facing the wall.
2. Lay the second plank flat on the floor with the short edge joint aligned directly over the groove of the first plank.
3. Apply downward force with thumbs to connect the two planks together.
4. Continue in this manner until the first row is complete. You will have to cut the last plank to complete the row.
5. Use the remainder of the last plank of the first row to start the second row provided that it is a minimum of 16" (40cm) long.

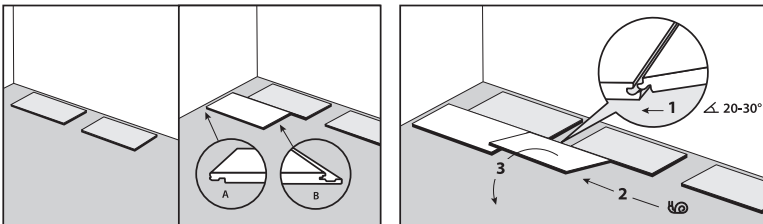

It's important that the long edges of the first row be perfectly straight and aligned in order to facilitate ease of installation of all other rows.

**TIP:** You can use an extra plank as an alignment tool. Once you install planks of your first row together, temporarily install an extra plank that spans both first row planks you want to align. This extra plank will automatically align the first row plank's long edges. Do this down the length of your first row. The alignment planks are removed prior to continuing with your installation.

## INSTALLATION PROCEDURE CONTINUED

### ALL OTHER ROWS

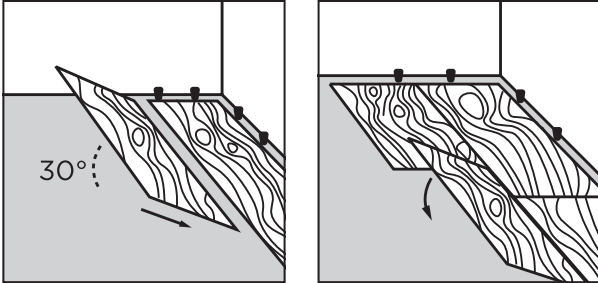

1. To install the first plank of the second row, place its long edge tongue into the previous row's long edge groove.
2. Lift the long edge groove side only to approximately a 30° angle so the edge you're holding is lifted off the floor, but the opposing long edge is resting in the previous row's groove.
3. Lower the plank to lock it into the previous row (a slight up/down, oscillating movement together with some force in the direction of the previous row may help to lower the plank).

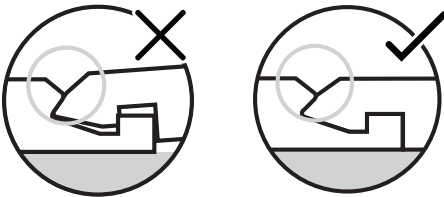

**TIP: Inspect the width of the long side bevel for uniformity. If the bevel is not even on both sides the connection is not correct.**

4. To install the remaining planks, first install the long edge of the second plank to the previous row.
5. Before lowering the plank, make sure its short end tongue overlaps with the previous plank's short end groove.
6. Lower the plank slowly (a short oscillating or up-and-down motion may help to seat the plank into the proper position).
7. Apply pressure to the plank's short edge starting close to the previous row and then engaging towards yourself across the width so as to activate the MegaLoc locking mechanism.
  - i. Thumb pressure should lock the plank in place but if more pressure is required, light tapping with a mallet is acceptable. Do not tap directly onto the installed planks. Place a scrap piece on top of the joint you are working on to tap on.
  - ii. Inspect every joint to ensure it is properly locked. Height differences from plank to plank at the joints is a sign of joints not being properly locked or damaged

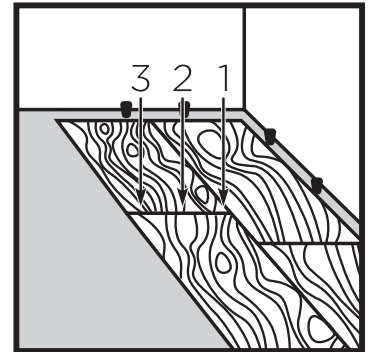

**NOTE: Planks are designed to interlock easily and with a small amount of pressure; if this is not the case, inspect the connection system for damage or debris.**

8. Continue in this manner until your installation is complete.
9. Remove all spacers.
10. Install quarter rounds, base boards and all other moldings.
11. Clean the floor and inspect it to ensure all joints are locked in place.

## INSTALLATION PROCEDURE CONTINUED

### PLANK REMOVAL

- To remove planks, lift the long edge of the last installed row all at once to approximately 30 degrees in order to disconnect the long edge installation mechanism.
- Once this row has been removed, disconnect each individual plank from one another by starting at the right-most plank and sliding it horizontally to disengage it from the previous plank.
- If you plan to re-install them, care should be taken so as not to damage the installation mechanism.

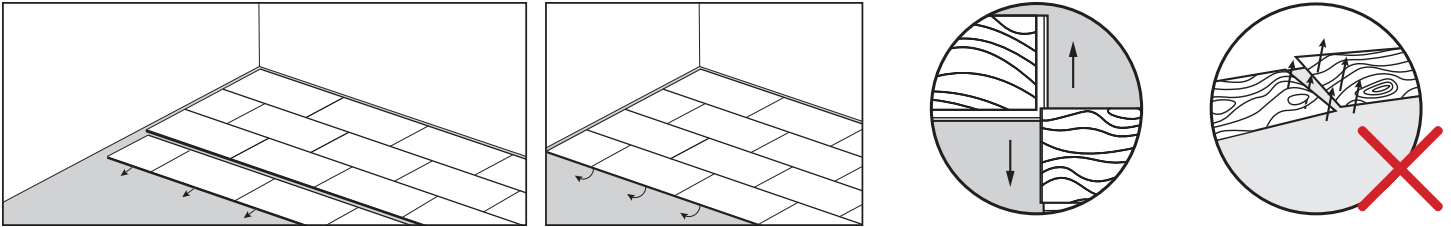

## RECOMMENDATIONS FOR WET AREA INSTALLATION

When installing in moisture prone areas (eg. kitchens, bathrooms, entryways), seal all expansion spaces with compressible PE foam backer rod and 100% neutral cure flexible silicone caulk as described in the following procedure.

**NOTE: Ceramin® is not a water barrier. When excessive moisture accumulates in buildings or on building materials, mold and/or mildew growth can occur. Care should be taken to address any moisture related issues prior to installing Ceramin®.**

**NOTE: Do not use acrylic based caulks as they are rigid and will prevent the floor from expanding and contracting. Use only neutral curing 100% flexible silicone caulk. Do not use acetoxysilicone caulks as they may damage Ceramin®.**

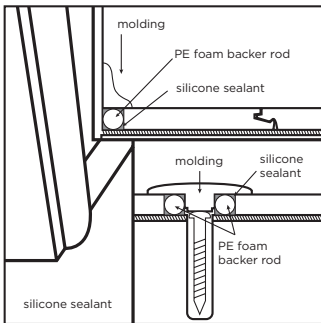

### PROCEDURE:

1. Insert 1/4" (6mm) compressible PE foam backer rod into room perimeter expansion space and cover completely with flexible silicone caulk.
2. Insert 1/4" (6mm) compressible PE foam backer rod at transitions and cover completely with flexible silicone caulk.
3. Use 100% flexible neutral cure silicone caulking around door frames and other fixed objects (eg. plumbing).
4. Install baseboards, quarter-rounds or other applicable moldings and immediately wipe up excess caulk.
5. Ensure baseboards or quarter-rounds are attached to walls, not floors.

**Tip: for ease of installation use PE Foam backer with a diameter closest to the floor's overall thickness.**



SCAN TO REGISTER  
YOUR PRODUCT